

The Bible

The Bible has 2 parts:

- Old Testament
- New Testament

Christ is the central figure of Scripture. His birth marks the division of time in Western civilization: B.C. and A.D. “B.C.” stands for “Before Christ” — before the incarnate Christ appeared on the earth. “A.D.” stands for the Latin *Anno Domini*: “In the year of the Lord.”

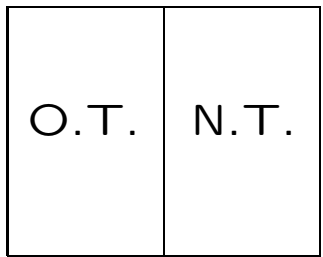

B.C.

A.D.

O-L-D	T-E-S-T-A-M-E-N-T	
3	9 (letters)	39 books
N-E-W	T-E-S-T-A-M-E-N-T	
3	9 (letters)	<u>27 books</u>
	×	66 books

Old & New Testaments

A testament is like a will, expressing someone's intentions for his children and heirs. It's often a written document meant to convey the most important things in life. The Old and New Testaments are God's written will, His purpose and plan of salvation for the world.

B.C.
5 Law
12 History
5 Poetry
5 Major Prophets
12 Minor Prophets

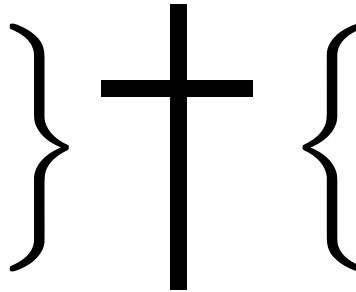

A.D.
Gospels 4
History 1
Pauline Epistles 13
General Epistles 8
Prophecy 1

The Old Testament Points to Christ
The New Testament Reveals Christ

In the Old Testament the new lies hidden, in the New Testament the old laid open. (St. Augustine)

Verbal Inspiration

God told the writers:

- What to write
- When to write

The Bible is ...

- **inerrant** — contains no errors
- **infallible** — cannot make mistakes
- **reliable**
- **trustworthy**
- **fully authoritative**

The Holy Trinity

Three-in-One

One-in-Three

The Father is God, the Son is God, the Holy Spirit is God, yet there are not three Gods, but one God.

Illustrations will always limp, but they may help us grasp what the Bible teaches.

A Glass of Ice Water

One substance (H_2O) in three states:

- Gas (vapor)
- Solid (ice)
- Liquid (water)

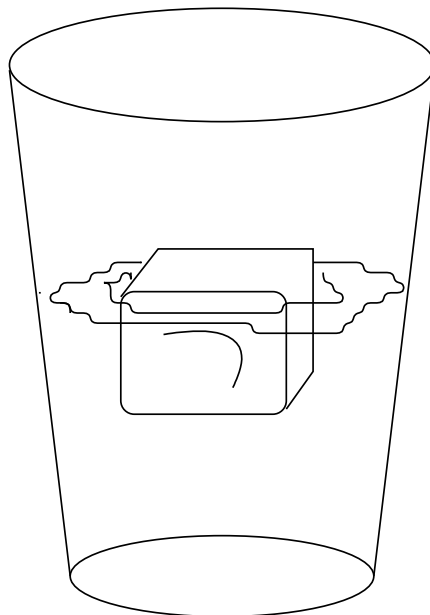

A Glass of Kool-Aid

Three ingredients in one drink:

- Water
- Flavoring
- Sugar

The Tree of Sin

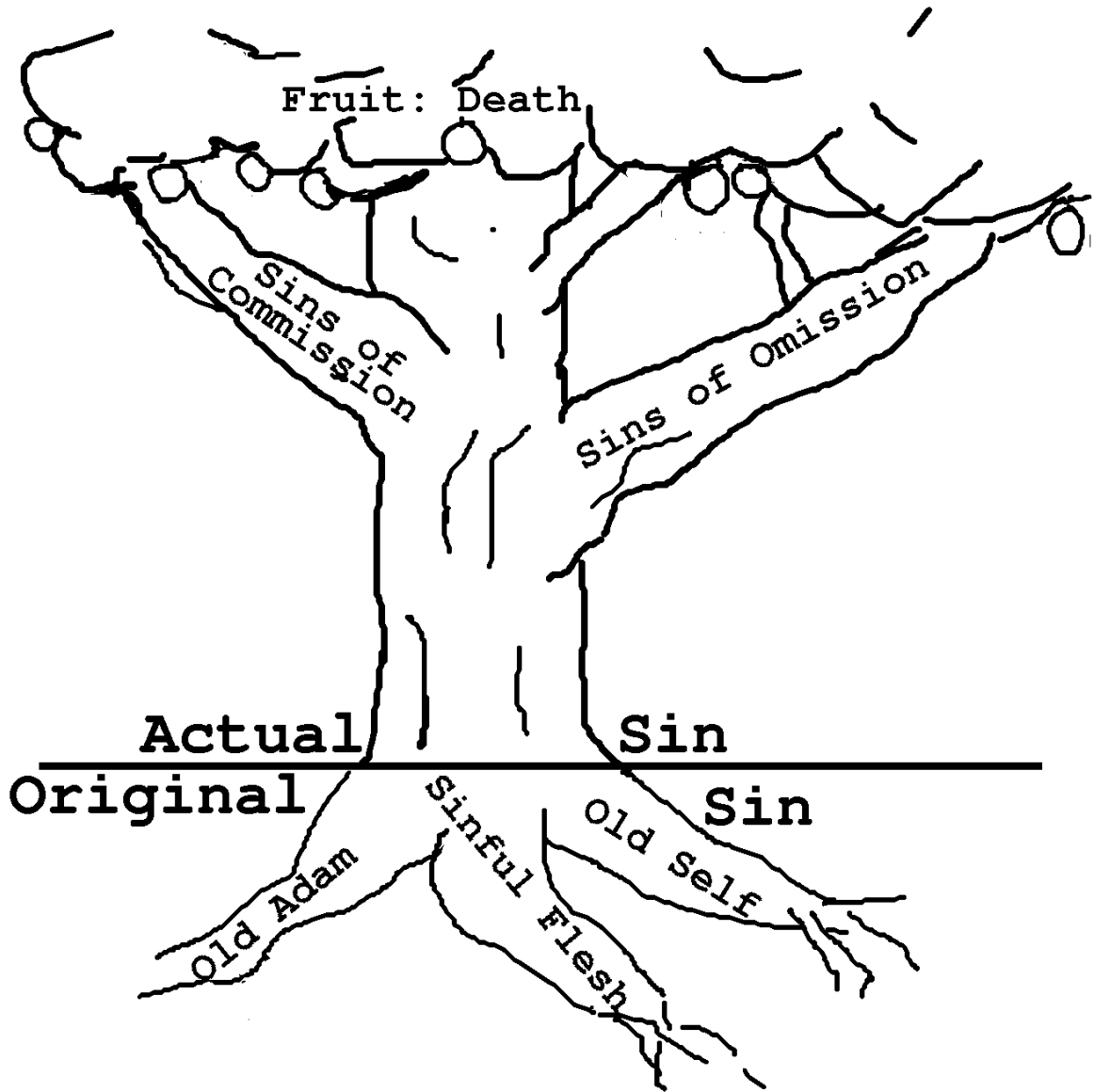

- There are 2 kinds of sin: original (hidden), and actual (visible)
- There are 2 kinds of actual sin: sins of commission (sins we do), and sins of omission (commands we fail to do)
- The ultimate fruit of all sin is death.

Law

Tells us what we are to do
Convicts us of sin
S.O.S. for the impenitent
Serves as a guide for believers

Penitent: (adj.) recognizing one's sinfulness, abandoning sinful ways, and desiring God's forgiveness in Christ.

LAW **S** hows **O** ur **S** in

God's Word Says:

Live
According to My
Will

and Gospel

Law

Gospel

Tells us what God has done

Saves us

S.O.S. for the penitent

Creates a living faith

GOSPEL

hows

ur

avior

God's
Only-begotten
Son
Purchased
Eternal
Life

The Grace of God

God's

Riches

At = God's Undeserved Love

Christ's

Expense

Ephesians 2:8–9 For by grace you have been saved through faith, and that not of yourselves; it is the gift of God, not of works, lest anyone should boast.

Romans 11:6 And if by grace, then it is no longer of works; otherwise grace is no longer grace. But if it is of works, it is no longer grace; otherwise work is no longer work.

The Watchwords of the Reformation

We are saved by ...

Sola Gratia (grace alone)

... through ...

Sola Fide (faith alone)

... revealed in ...

Sola Scriptura (scripture alone)

The Two Natures in Christ

Divine

He is true God, begotten of the Father from eternity.

He has divine names, divine attributes, and does divine works

He receives divine honor and glory

Necessary for Him to overcome sin, death, and the devil for us.

Human

He is true man, born of the Virgin Mary

He lives as a true man, with human feelings and actions

Necessary for Him to be under the Law and fulfill it for us, and to be able to suffer and die as our substitute

Two natures in One person.

Some illustrations (imperfect, but helpful):

- iron and fire (heat) — The iron has several attributes of fire when it's heated up, but only because of its union with the fire (its hot temperature).
- body and soul — God made us with a soul, so that we have attributes that the other creatures do not have, but only as long as our bodies are united with our souls.

The Work of Christ

Two *states*:

- Humiliation

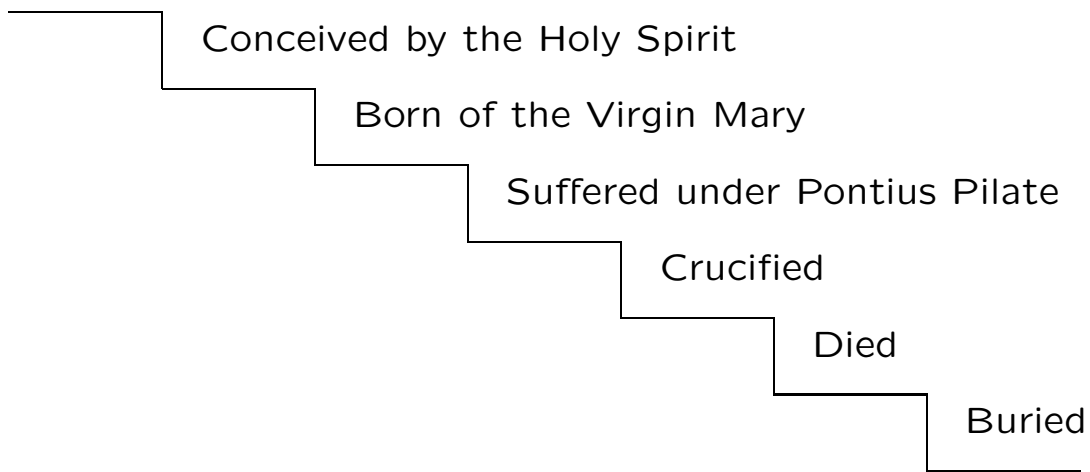

- Exaltation

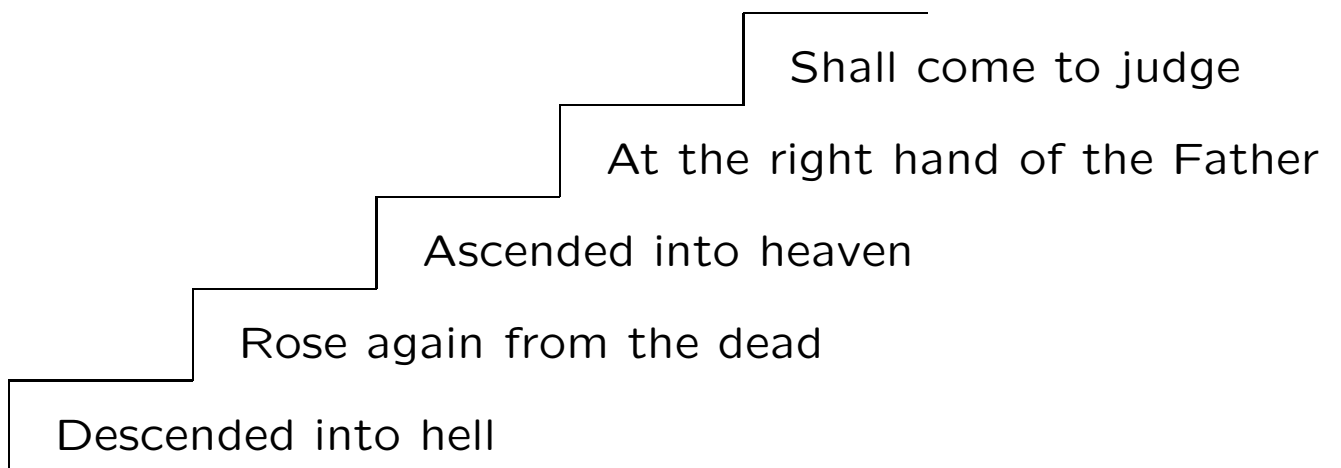

The Means of Grace

Means a way to get something done

Means of Grace the way God gets His gifts of grace to us individually

God has promised to give us forgiveness of sins, life, and salvation through three means:

- Word (Gospel) *May be:*
 - read from the Bible or sources based on the Bible
 - heard in a sermon or devotion
 - received in the absolution through your pastor or any fellow Christian

John 20:23 If you forgive the sins of any, they are forgiven them; if you retain the sins of any, they are retained.

- Baptism
 - Administered once
 - Used throughout life

- The Sacrament of the Altar
 - Contains the real body and blood of Christ as the words say
 - Gives forgiveness of sins
 - Can be received unworthily, to one's judgment

Six Principles of Christian Stewardship

1. God owns everything. (Psalm 24:1, Haggai 2:8)
2. I, too, belong to God. (Psalm 139:14, 1 Corinthians 6:19)
3. All that I am & all that I have is God's. As His steward, I am to use it all to God's glory. (1 Corinthians 6:20, John 9:4, 1 Peter 4:10, 1 Corinthians 16:2)
4. God wants me to be faithful in my stewardship. (1 Corinthians 4:2)
5. A faithful steward lives happily in Christ. (John 15:10–11)
6. My primary motive for good stewardship is God's grace in Christ. (2 Corinthians 5:14–15)

The Holy Christian Church

- invisible to humans, visible to God alone
- not limited to any visible church
- composed of all who have saving faith, regardless of doctrinal errors
- found wherever the Word and Sacraments are taught and administered according to God's will

Large Circle: The Holy Christian Church

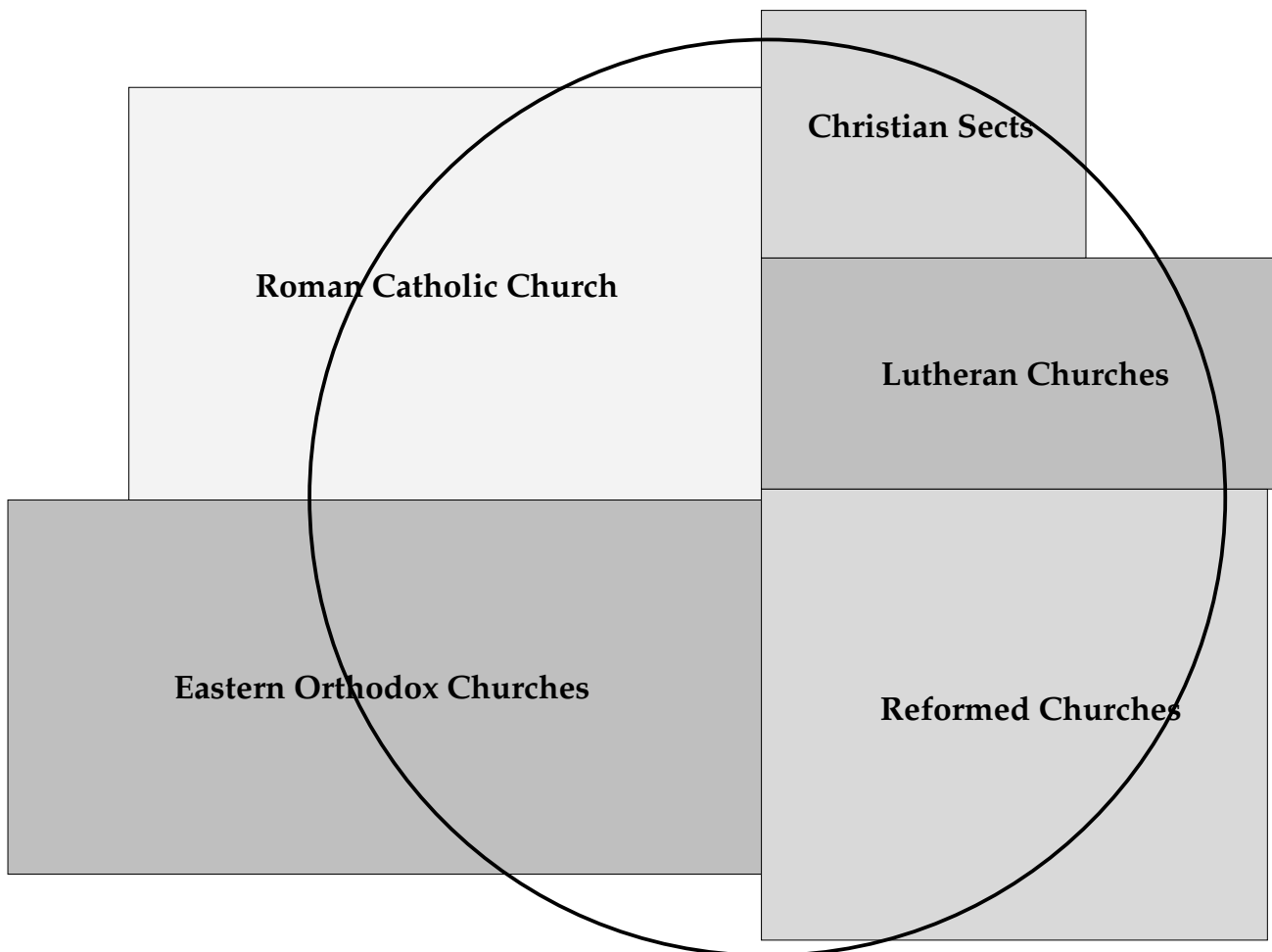

(Not intended to represent actual proportions.)